

5

2° Tappa
2^{ème} Etape
2ND Section

TARGA

63°

EFLORIO

RALLYE
INTERNAZIONALE
DI SICILIA

VU DAFIERI
PER ISSUTI

16 - 17 - 18 MARZO 1979

FIAT 131 ABARTH GR. 4 JOLLY CLUB



CAMPIONATO D'EUROPA RALLIES CONDUTTORI





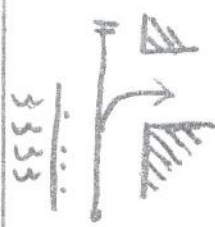
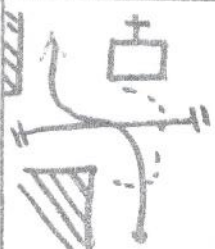

carnet de bord offerto dalla

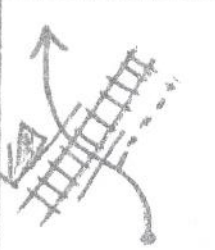
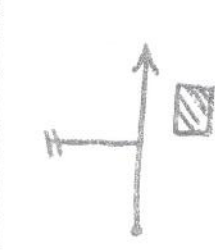



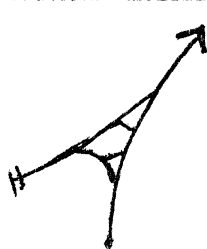
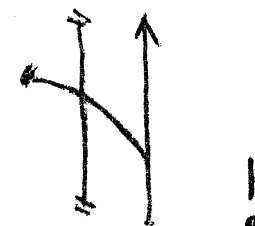

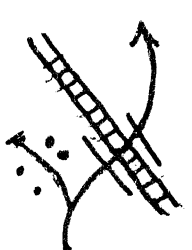
kléber



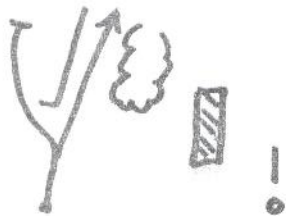
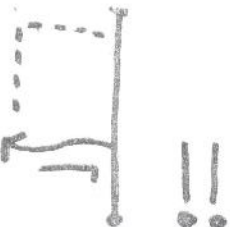
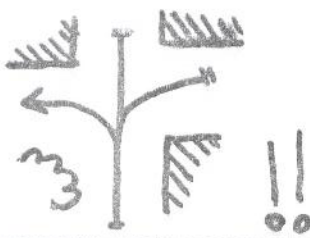

| | | | |
|-------|-------|--|--|
| 0.000 | | | C.O.21 → C.O.22 Km 50 CEFALU → TERMINI 1 ^a Km 36.50/60' +20' |
| 0.000 | 0.000 | | LUNGOMARE G. COLOMBO START 2 ^a TAPPA (S) 2 nd SECTION |
| 0.030 | 0.030 | |  Km 35 Termini Luc. |
| 0.160 | 0.130 | |  |
| 0.290 | 0.130 | |  PALERMO → SS113 |
| 1.230 | 0.940 | |  SS113 |
| 2.150 | 0.920 | |  S. LUCIA SS113 |



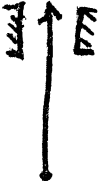



| | | | |
|--------|-------|--|-------|
| 4.800 | 2.650 |  | SS113 |
| 5.010 | 0.210 |  | SS143 |
| 9.990 | 4.980 |  | SS143 |
| 14.990 | 5.000 |  | SS113 |
| 18.920 | 3.930 |  | SS113 |
| 21.330 | 2.410 |  | SS113 |
| 25.080 | 3.750 |  | SS113 |



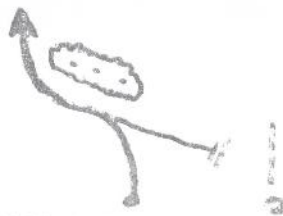



PALERHO

| | | | |
|--------|-------|---|--|
| 26.380 | 1.300 |  | SS113 |
| 30.620 | 4.240 |  | SS113 |
| 33.620 | 3.000 |  TERMINI | SS113 |
| 34.750 | 1.130 |  STAZIONE STATION | SS113 |
| 34.910 | 0.160 |  !! | S Km 13 dopo PS A/3 CACCATO |
| 35.210 | 0.300 |  !! | |
| 35.350 | 0.140 |  | |

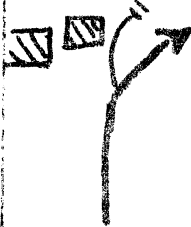

| | | | |
|--------|--|-------|---|
| 36.380 | | 1.030 |  C.O. 22 |
| • | | | |
| | | | |
| | | | |
| | | | |
| | | | |
| | | | |





| | | |
|--------|-------|---|
| 0.000 | +10' | C.O. 22 + C.O. 23 Km 32,500 TERMINI → MONTEMAGGIORE SCALO 39' Km 32 ³⁰ /39' +9' |
| 0.040 | 0.040 | START P.S. A/3 "TERMINI" Km 10,600 in 6' |
| 3.110 | 3.070 |  1 FRANA • LAND SLIDE |
| 7.690 | 4.580 |  |
| 9.760 | 2.070 |  |
| 10.590 | 0.830 |  FINE END P.S. A/3 |
| 10.870 | 0.280 |  STOP |

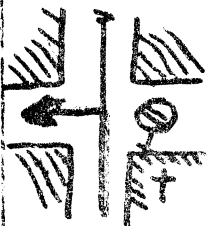
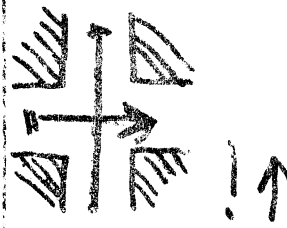
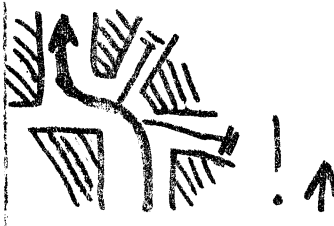

| | | | |
|--------|-------|---|---|
| 11.230 | 0.360 |  | SS 285 |
| 11.860 | 0.630 |  | SS 285 CACCAMO <i>(S) Km 24 dopo PS B/3 MONTENAPOLITANO</i> |
| 13.220 | 1.360 |  | SS 285 ENNA AGRIGENTO |
| 14.180 | 0.960 |  | SS 285 CACCAMO |
| 15.600 | 1.420 |  | SS 285 ROCCAPALUMBA |
| 16.750 | 1.150 |  | SS 285 |
| 18.350 | 1.600 |  | CAVA QUARRY |

| | | |
|--------|-------|--|
| 19.040 | 0.690 |  <p>PANTICELLO SHALL BRIDGE</p> |
| 22.120 | 3.080 |  |
| 22.720 | 0.600 |  |
| 26.500 | 3.780 |  |
| 28.000 | 1.500 |  |
| 30.360 | 2.360 |  |
| 31,080 | 0.720 |  <p>ASTALTO SCOMESSO UNEWEED ROAD</p> |



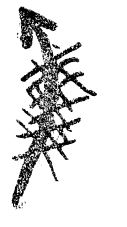

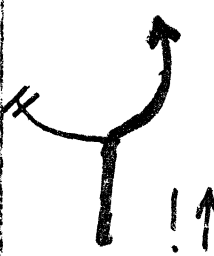
| | | | |
|--------|-------|--|--|
| 32.330 | 1.250 |  | C.023 DOPO IL PONTE AFTER THE BRIDGE |
| | | | |
| | | | |
| | | | |
| | | | |
| | | | |
| | | | |
| | | | |

| | | |
|-------|-------|---|
| 0.000 | + 7' | C. 023 → C. 024 km 2500 MONTEMAGGIORE SCALO → BIVIO VILLAGUERA 24 km 22 ⁵⁰ /27' (+ 7') |
| 0.070 | 0.070 | ↑ START P.S. B/3 "MONTEMAGGIORE" km 8 in <u>5'30"</u> |
| 0.440 | 0.370 | ⊥ ! |
| 4.630 | 4.190 | ↙ |
| 8.020 | 3.390 | ↑  FINE END P.S. B/3 |
| 8.320 | 0.300 | ↑  ! <u>STOP</u> |
| 9.640 | 1.320 | ↘  MONTEMAGGIORE ⑤ km 38 CALTAVUTURO Parco assistenza obolo PS B/3 |

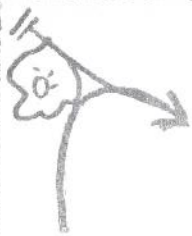

| | | | |
|--------|-------|---|----------------------------|
| 10.190 | 0.550 |  | |
| 10.290 | 0.100 |  | |
| 10.350 | 0.060 |  | |
| 11.180 | 0.830 |  | MONTENAGGIORE |
| 12.750 | 1.570 |  | ALINHUSA |
| 13.340 | 0.590 |  | ALINHUSA |
| 13.960 | 0.620 |  | FRANA LANDSLIDE |

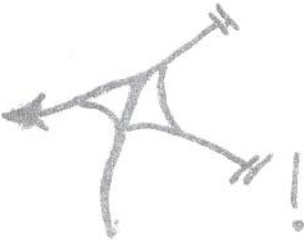

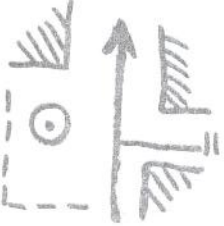

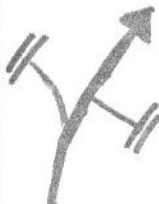
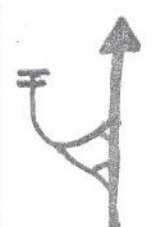

| | | |
|--------|-------|---|
| 19.540 | 5.580 |  <p>SS 120</p> <p>YOU ARE ENTERING IN TARGA FLORIOTRACK.</p> |
| 21.180 | 1.640 |  <p>SS 120</p> <p>C.0.24</p> |
| | | |
| | | |
| | | |
| | | |
| | | |





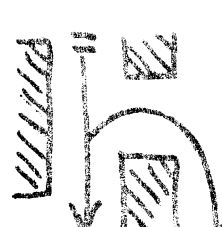

| | | |
|--------|--------|--|
| 0.000 | +13' | C.024 → C.025 km 30 BIVIO VILLAUREA → CALTAVUTURO (ASSIST.) 36' Km 28/36' +12' |
| 0.100 | 0.100 | START P.S. C/3 SS120 km 18 mi "TARGA" |
| 11.990 | 11.890 | SCLAFANI BAGNI SS120 !!! ↑ |
| 12.040 | 0.050 | |
| 13.620 | 1.580 | |
| 14.390 | 0.770 | !! ↑ |
| 14.600 | 0.210 | !! ↑ |





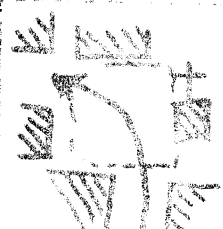

| | | | |
|--------------|-------|--|--|
| 15.950 \$ | 1.350 |  | |
| 17.760 | 1.810 |  | FINE, P.S. C/3 END |
| 18.330 | 0.570 |  | ABBEVERATDIO DRINKING TROUGH STOP |
| 23.170 | 4.840 |  | CALTAVUTURO |
| 26.770 | 3.600 |  | SS.120 |
| 27.790 | 1.020 |  | CALTAVUTURO SS120 |
| | 0.270 |  | C.025 PARCO ASSISTENZA ASSISTANCE AREA 20' |



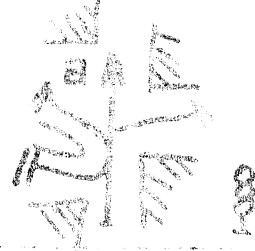

| | | |
|-------|-------|---|
| 0.000 | 0.130 | ↑ C.026 FINE FIRE ASSISTENZA END ASSISTANCE AREA |
| 0.000 | 0.430 | ▣ GULF ↑ C.027 |
| | | |
| | | |
| | | |
| | | |
| | | |
| | | |





| | | |
|--------|-------|---|
| 0.000 | | C.O.27 → C.O. 28 Km 65 CALTAVUTURO → BIVIO FERLA 1 ^h 18' Km 52 ²⁰ / 1 ^h 18' (+25') |
| 0.050 | 0.050 | START P.S. D3 ES/100 ↑ Km 19 in 11' "CALTAVUTURO" |
| 1.900 | 1.850 |  COLLESANO 25 SS/100 |
| 8.780 | 6.880 |  |
| 9.640 | 0.860 |  POLIZZI GENEROSA SCILLATO COLLESANO |
| 10.010 | 0.370 |  POLIZZI GENEROSA COLLESANO |
| 12.070 | 2.060 |  COLLESANO ! ↑ |

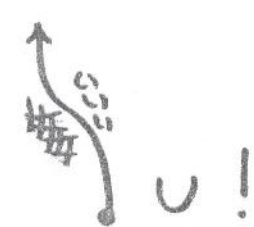

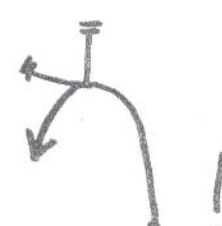

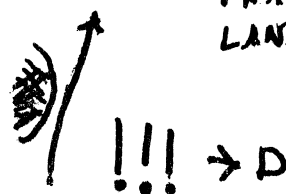
| | | |
|--------|-------|---|
| 17.190 | 5.120 |  |
| 18.740 | 1.550 |  <p>ALLA CASA ROSSA TO RED HOUSE</p> <p>FINE P.S.D/3</p> |
| 18.940 | 0.200 |  <p>STOP</p> |
| 21.830 | 2.890 |  <p>COLLESAVO</p> |
| 22.080 | 0.250 |  |
| 22.500 | 0.420 |  <p>PALEANO</p> <p>SS13</p> |
| 22.660 | 0.160 |  |

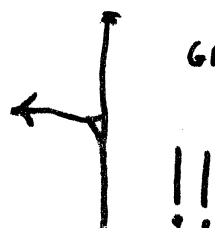

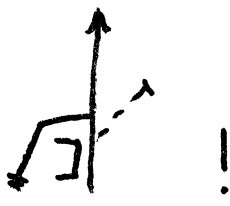
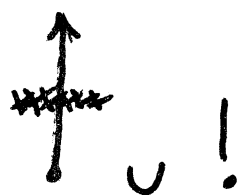

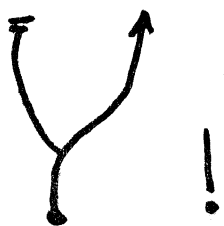
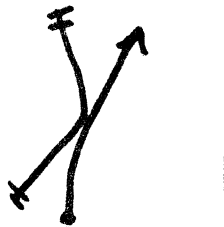
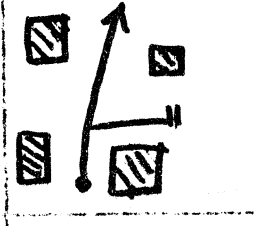
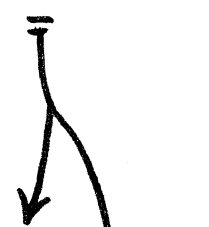
| | | | | |
|--------|-------|---|-------------|-------|
| 25.610 | 2.950 |  | PALEMO | |
| 29.860 | 4.250 |  | PALEMO | |
| 33.270 | 3.410 |  | CARPOFELICE | |
| 34.100 | 0.830 |  | PALEMO | |
| 35.330 | 1.230 |  | MESSINA | SS113 |
| 40.150 | 4.820 |  | MESSINA | SS113 |
| 45.040 | 4.890 |  | MESSINA | SS113 |

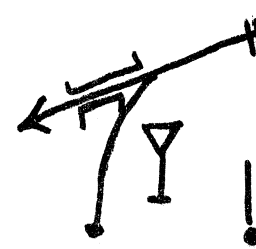



| | | | | |
|--------|-------|---|---------|-----------------|
| 48.560 | 3.520 |  | BEVALU | SS43 |
| 49.470 | 0.910 |  | | SS43 |
| 49.540 | 0.070 |  | | SS43 |
| 49.970 | 0.430 |  | MESSINA | SS43 |
| 51.100 | 1.130 |  | | SS43 |
| 51.680 | 0.580 |  | FERLA | SS43 |
| 52.230 | 0.550 |  | C.O. 28 | |

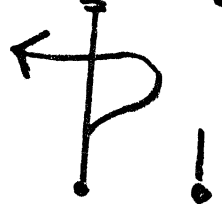



| | | |
|-------|-------|--|
| 0.000 | +6' | C.O. 28 → C.O. 29 <i>Key 20</i> BIVIO FERLA → S.P. 15 24' <i>Key 17⁶⁰/24'</i> +6' |
| 0.070 | 0.070 | START P.S. H/2 "FERLA" <i>Key 8,350 in 5'30"</i>  |
| 0.730 | 0.660 | FRANA LANDSLIDE !  |
| 1.070 | 0.340 | AVALLAMENTO BACK !  |
| 4.210 | 3.140 |  |
| 6.260 | 2.050 |  |
| 7.030 | 0.770 | !  |



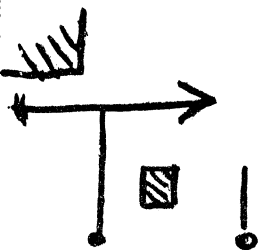

| | | | |
|-------|-------|--|---|
| 7.380 | 0.350 |  | FRANA LANDSLIDE x 200 MTS |
| 7.660 | 0.280 |  | FRANA LANDSLIDE |
| 7.730 | 0.070 |  | |
| 7.820 | 0.090 |  | STERRATO GRAVEL ROAD x 80 MTS |
| 8.350 | 0.530 |  | FINE END P.S. H/2 |
| 8.460 | 0.110 |  | STOP |
| 8.480 | 0.020 |  | GIRARE LA PAGINA SUBITO! TURN PAPER QUICKLY! |

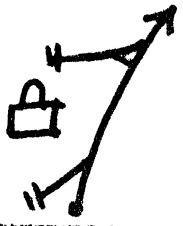



| | | |
|--------|-------|---|
| 8.500 | 0.020 |  |
| 9.050 | 0.550 |  |
| 9.310 | 0.260 |  |
| 9.670 | 0.360 |  |
| 10.910 | 1.240 |  FRANA LANDSLIDE |
| 12.250 | 1.340 |  SS113 |
| 14.650 | 2.400 |  SS113 |

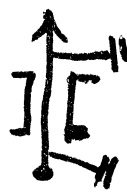

| | | | |
|--------|-------|---|--|
| 14.720 | 0.070 |  | SS13 INCROCIO VETTURE IN GARA CROSSING RACING CARS |
| 15.320 | 0.600 |  | SS13 |
| 16.450 | 1.130 |  | SS13 GIBILMANNA FINE INCROCIO VETTURE END CROSSING CARS |
| 17.250 | 0.800 |  | GIBILMANNA SP15 |
| 17.630 | 0.380 |  | SP15 C.O. 29 |
| | | | |
| | | | |

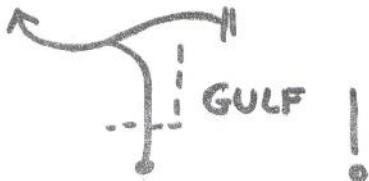
| | | |
|--------|-------|--|
| 0.000 | + 14' | C.O. 29 → C.O. 30 Km 30 S.P. 45 → LASCARI (ASSISTENZA) 36' Km 30/36' + 10' |
| 0.100 | 0.100 | START P.S. I/2 ^{SP45} "GIBILMANN" Km 29,400 19' |
| 7.700 | 7.600 |  ^{SP45} |
| 12.180 | 4.480 |  GRATTERI ^{SP45} |
| 12.770 | 0.590 |  GRATTERI ^{SP45} |
| 16.180 | 3.410 |  |
| 17.870 | 1.690 |  |

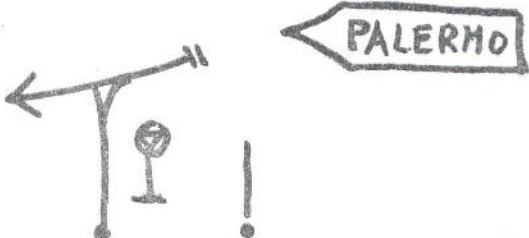

| | | |
|--------|-------|---|
| 17.970 | 0.100 |  |
| 18.100 | 0.130 |  |
| 18.440 | 0.340 |  |
| 20.060 | 1.620 | ↑ STERRATO GRAVEL ROAD |
| 20.180 | 0.120 |  |
| 20.790 | 0.610 | ↑ ASFALTO ASPHALTED ROAD |
| 21.520 | 0.730 |  |

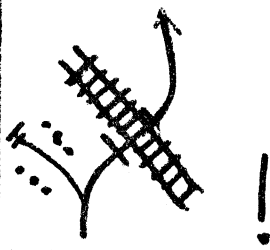

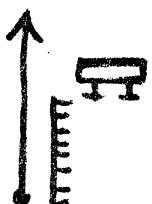
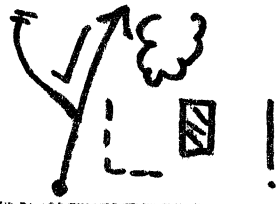
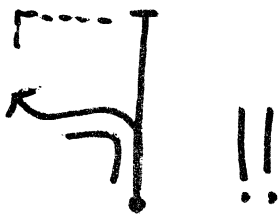

| | | |
|--------|-------|---|
| 24.080 | 2.560 |  |
| 29.390 | 5.310 |  FINE END P.S. I/2 |
| 29.490 | 0.100 |  LASCARI |
| 29.690 | 0.200 |  STOP |
| 30.000 | 0.310 |  C.O. 30 PARCO ASSISTENZA-ASSISTANCE PARK |
| | 0.100 |  C.O. 31 USCITA WAY OUT |
| | | |

| | | |
|--------|-------|---|
| 0.000 | + 10' | C.O. 31 → C.O. 32 Km 30 LASCARI → TERMINI IM. 36' Km 28 ³⁰ / 36' + 10' |
| 0.310 | 0.310 |  |
| 0.390 | 0.080 |  |
| 0.950 | 0.560 |  |
| 1.870 | 0.920 |  |
| 6.870 | 5.000 |  |
| 10.800 | 3.930 |  |





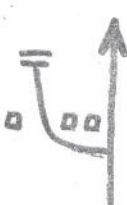

| | | | |
|--------|-------|--|-----------------------------|
| 13.210 | 2.410 |  | SS1B |
| 16.960 | 3.750 |  | SS1B |
| 18.260 | 1.300 |  | SS1B |
| 22.500 | 4.240 |  | SS1B |
| 25.500 | 3.000 |  | TERMINI SS1B |
| 26.630 | 1.130 |  | STAZIONE STATION SS1B |
| 26.790 | 0.160 |  | SS1B |

~~SS/13~~

| | | |
|--------|-------|---|
| 27.090 | 0.300 |  !! |
| 27.230 | 0.140 |  ! |
| 28.260 | 1.030 |  C.O. 32 |
| | | |
| | | |
| | | |
| | | |
| | | |







| | | |
|--------|-------|---|
| 0.000 | + 10' | C.O.32 → C.O.33 Km 32,500 TERMINI → MONTENAGGIORE SCALO 39' Km 32 ³⁰ /39' (+9') |
| 0.040 | 0.040 | START P.S. A/4 "TERMINI"  Km 10,600 in 6' |
| 3.110 | 3.070 |  1 FRANA • LANDSLIDE |
| 7.690 | 4.580 |  |
| 9.760 | 2.070 |  |
| 10.590 | 0.830 |  FINE : P.S. A/4 END : |
| 10.870 | 0.280 |  STOP |

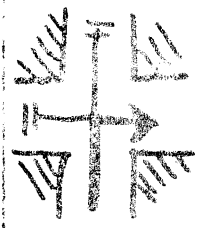

| | | | |
|--------|-------|--|--------------------------|
| | | | SS 285 |
| 11.230 | 0.360 | | |
| 11.860 | 0.630 | | CACCAMO SS 285 |
| 13.220 | 1.360 | | ENNA AGRIGENTO SS 285 |
| 14.180 | 0.960 | | CACCAMO SS 285 |
| 15.600 | 1.420 | | ROCCAPALUNDA SS 285 |
| 16.750 | 1.150 | | SS 285 |
| 18.350 | 1.600 | | CAVA QUARRY |





| | | |
|--------|-------|--|
| 19.040 | 0.690 |  <p>PONTICELLO + SMALL BRIDGE</p> |
| 22.120 | 3.080 |  |
| 22.720 | 0.600 |  |
| 26.500 | 3.780 |  |
| 28.000 | 1.500 |  |
| 30.360 | 2.360 |  |
| 31.080 | 0.720 |  <p>ASFALTO SCONNESSO UNEWED ROAD</p> |

| | | | |
|--------|-------|--|--|
| 32.330 | 1.250 |  | C.O. 33 DOPO IL PONTE AFTER THE BRIDGE |
| | | | |
| | | | |
| | | | |
| | | | |
| | | | |
| | | | |
| | | | |
| | | | |
| | | | |

| | | |
|------------|-------|--|
| 0.000 ↓ | + 7' | C.O.33 → C.O.34 Km 2,500 MONTENAGGIORE SCALO → BIGIO VILLAUREA 30 27 Km 22 ⁵⁰ /27' (+ 7') |
| 0.070 | 0.070 | ↑ START P.S. B/4 "MONTENAGGIORE" Km 8 in 5'30" |
| 0.440 | 0.370 | ↗ ! |
| 4.630 | 4.190 | ↖ ! |
| 8.020 | 3.390 | ↑ ! FINE P.S. B/4 END |
| 8.320 | 0.300 | ↑ ! <u>STOP</u> |
| 9.640 | 1.320 | ↗ ! MONTENAGGIORE |





| | | | |
|--------|-------|---|-------------------------|
| 10.190 | 0.550 |  | |
| 10.290 | 0.100 |  | ! ↑ |
| 10.350 | 0.060 |  | ! ↑ |
| 11.180 | 0.830 |  | MONTENAGGIORE |
| 12.750 | 1.570 |  | ALIMINUSA |
| 13.340 | 0.590 |  | ALIMINUSA |
| 13.960 | 0.620 |  | FRANA LANDSLIDE ! |

| | | |
|--------|-------|--|
| 19.540 | 5.580 |  <p>(*)</p> <p>SS 120</p> <p>YOU ARE ENTERING IN TARGA FLORIO TRACK.</p> |
| 21.180 | 1.640 |  <p>C. 0.34</p> <p>SS 120</p> |
| | | |
| | | <p>(*) SOLO PER IL TROFEO AUTOBIANCHI:</p>  <p>SEGUIRE QUESTA INDICAZIONE E ANDARE A PAG. 57 DEL RADAR.</p> |
| | | |
| | | |
| | | |













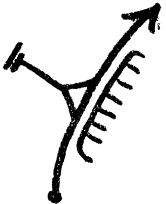

| | | |
|--------|--------|--|
| 0.000 | +13' | C.034 → C.035 Km 30 BIVIO VILLAUREA → CALTAVUTURO (ASSIST.) 36' Km 28/36' (+12') |
| 0.100 | 0.100 | START P.S. C/4 SS120 "TARGA" Km 18 in 11'50" |
| 11.990 | 11.890 | SCLAFANI BAGNI SS120  |
| 12.040 | 0.050 |  |
| 13.620 | 1.580 |  |
| 14.390 | 0.770 |  |
| 14.600 | 0.210 |  |

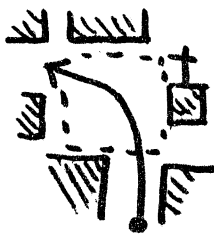
| | | | |
|--------|-------|--|--|
| 15.950 | 1.350 | | |
| 17.760 | 1.810 | | FINE END P.S. C./4 |
| 18.330 | 0.570 | | ABBEVERATTO DRINKING TROUGH STOP |
| 23.170 | 4.840 | | CALTAVUTURO |
| 26.770 | 3.600 | | SS.120 |
| 27.790 | 1.020 | | CALTAVUTURO SS120 |
| | 0.270 | | C.035 PARCO ASSISTENZA ASSISTANCE AREA 20' |

| | | |
|-------|-------|---|
| 0.000 | 0.130 | ↑ C.O.36 FINE PARCO ASSISTENZA END ASSISTANCE AREA |
| 0.000 | 0.430 | ☒ ↑ GULF C.O.37 |
| | | |
| | | |
| | | |
| | | |
| | | |

| | | |
|--------|-------|---|
| 0.000 | | C.O. 37 → C.O. 38 km 60 CALTAVUTURO → COLLESANO Hotel S. Lucia 1 ^h 12' Km 47.80 / 1^h 12' (+25') |
| 0.050 | 0.050 | START P.S. D/4 (reali 47.70) "CALTAVUTURO" Km 65 / 1 ^h 18' vechi circolare |
| 1.900 | 1.850 |  COLLESANO 25 SS120 |
| 8.780 | 6.880 |  |
| 9.640 | 0.860 |  POLIZZI GENEROSA SCILLATO COLLESANO |
| 10.010 | 0.370 |  POLIZZI GENEROSA COLLESANO |
| 12.070 | 2.060 |  COLLESANO ! ↑ |

| | | |
|--------|-------|---|
| 17.190 | 5.120 | |
| 18.740 | 1.550 | <p>ALLA CASA ROSSA TO RED HOUSE</p> <p>FINE END P.S.D/4</p> |
| 18.940 | 0.200 | <p>STOP</p> |
| 21.830 | 2.890 | <p>COLLESANO</p> |
| 22.080 | 0.250 | |
| 22.500 | 0.420 | <p>PALERMO SS113</p> <p>!!</p> |
| 22.660 | 0.160 | |

| | | | |
|--------|-------|---|--|
| 25.610 | 2.950 |  |  |
| 29.860 | 4.250 |  |  |
| 33.270 | 3.410 |  |  |
| 34.100 | 0.830 |  |  |
| 35.330 | 1.230 |  |  SS113 |
| 40.150 | 4.820 |  |  SS113 |
| 45.040 | 4.890 |  |  SS113 |

SS/15

47.730

2.690



CO38







47.830



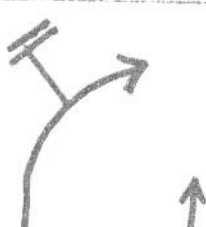

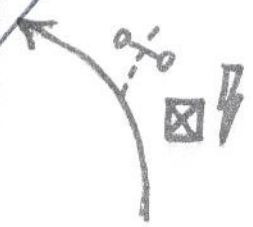

0.100

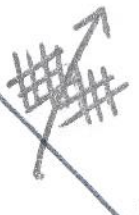

C.O. 38

CO R2 Hotel S. Lucie 15'

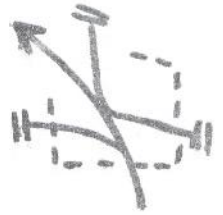
| | | |
|-------|-------|--|
| 0.000 | | C.O.38 → C.O.39 kuu 15 Hts. LUCIA → BIVIO FERLA Riviera 30 18' Km 22 ⁵⁰ / 27' + 10' |
| 0.060 | 0.060 |  Vedi pag 44 START P.S. G/4 "SANTALUCIA" |
| 0.560 | 0.500 |  |
| 3.450 | 2.890 |   |
| 4.570 | 1.120 |  |
| 6.040 | 1.470 |  |
| 6.550 | 0.510 |  |

| | | | |
|--------|-------|--|-----------------------------|
| 7.710 | 1.160 |  | FRANA LANDSLIDE ! |
| 7.910 | 0.200 |  | A SFALTO A SPHALTED ROAD |
| 8.330 | 0.220 |  | FRANA LANDSLIDE !!! |
| 10.230 | 1.900 |  | FINE END D.S. G/2 |
| 10.440 | 0.210 |  | CEPALU STOP |
| 18.660 | 8.220 |  | CEPALU ! |
| 19.460 | 0.800 |  | MESSINA SS113 |

SS113

20.590

1.130



~~SS113~~

21.170

0.580

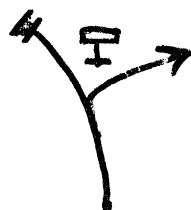

FERLA











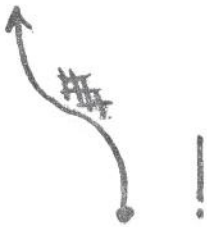
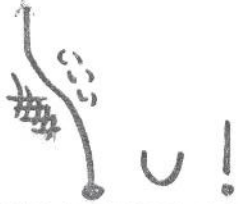

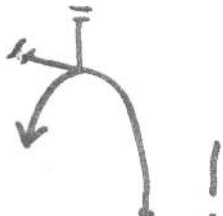
21.720



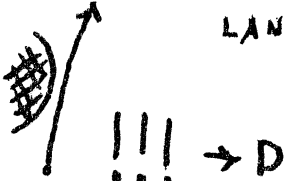



0.550







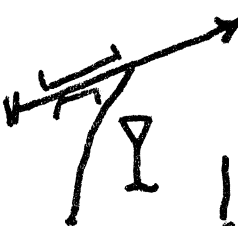

C.O. 39





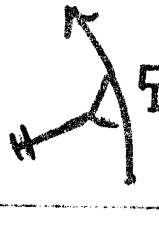

| | | |
|-------|-------|--|
| 0.000 | | C.O.39 → C.O.40 km 35 BIVIO FERLA → CASTELBUONO 42' km 30/42' + 12' |
| 0.070 | 0.070 | START P.S. H/3 "FERLA"  |
| 0.730 | 0.660 | FRANA LANDSLIDE  |
| 1.070 | 0.340 | AWALLAMENTO BACK  |
| 4.210 | 3.140 |  |
| 6.260 | 2.050 |  |
| 7.030 | 0.770 |  |

| | | | |
|-------|-------|--|---|
| 7.380 | 0.350 |  | FRANA LANDSLIDE x 200 MTS |
| 7.660 | 0.280 |  | FRANA LANDSLIDE |
| 7.730 | 0.070 |  | |
| 7.820 | 0.090 |  | STERRATO GRAVEL ROAD x 80 MTS |
| 8.350 | 0.530 |  | FINE END P.S. H/3 |
| 8.460 | 0.110 |  | STOP |
| 8 480 | 0.020 |  | GIRARE LA PAGINA SUBITO! TURN PAPER QUICKLY! |

| | | | |
|--------|-------|--|-------|
| | 60' | | |
| 8.500 | 0.020 |  | ! |
| 9.050 | 0.550 |  | ! |
| 9.310 | 0.260 |  | ! |
| 9.670 | 0.360 |  | ! |
| 10.910 | 1.240 |  | !! |
| | 2'30" | | SS113 |
| 12.250 | 1.340 |  | ! |
| | | | SS113 |
| 13.350 | 2.100 |  | ! |

FRANA
LANDSLIDE

| | | | |
|--------|-------|---|---------------------------|
| 15.470 | 2.120 |  | SS113 |
| 15.570 | 0.100 |  | SS113 SS186 |
| 18.990 | 3.420 |  | SS186 |
| 21.370 | 2.380 |  | CAVA QUARRY SS186 |
| 22.110 | 0.710 |  | SS186 |
| 22.540 | 0.430 |  | SS186 |
| 26.020 | 3.480 |  | SS186 |

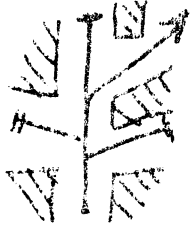

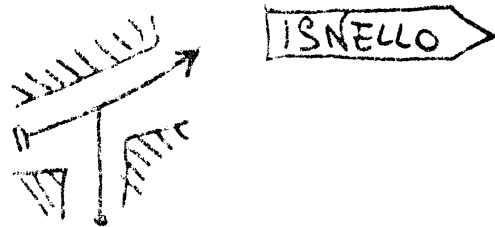
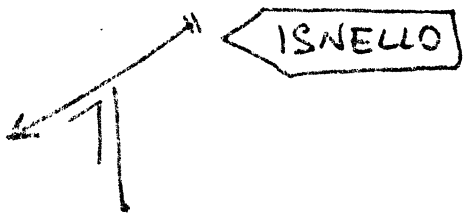
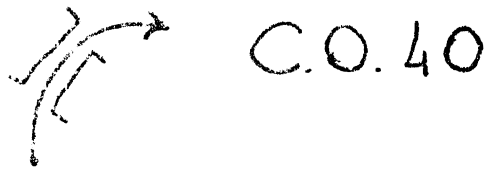

| | | | |
|--------|-------|---|------------------|
| 26.460 | 0.440 |  | SS186 |
| 27.390 | 0.930 |  | SS186 |
| 28.140 | 0.750 |  | SS186 |
| 28.250 | 0.110 |  GERACI SICULO | SS186 |
| 28.470 | 0.220 |  CASTEL BUONO | SS186 |
| 29.050 | 0.580 |  ISNELLO ! | SS186 |
| 29.210 | 0.160 |  ISNELLO ! PAVE' COBBLING PAVING | |

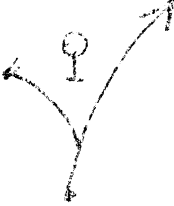

| | | |
|--------|-------|--|
| 29.400 | 0.190 |  |
| 29.630 | 0.230 |  |
| 29.770 | 0.140 |  |
| | | |
| | | |
| | | |
| | | |

| | | |
|--------|--------------|---|
| 0.000 | +10' | C.O. 40 → C.O. 41 Km 20 CASTELBUONO → PIANOFATE 24' |
| 0.050 | 0.050 | START P.S. "L" "CASTELBUONO" Km 9 L 6' |
| 6.740 | 6.690 | |
| 9.090 | 2.350 | FINE P.S. L END |
| 9.220 | 0.130 00' | |
| 15.820 | 6.600 | FRANA LANDSLIDE |
| 16.150 | 6' 0.330 | GRATTERI C.O. 41 |

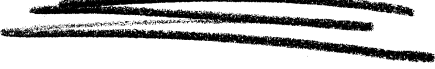
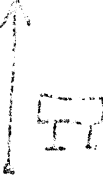

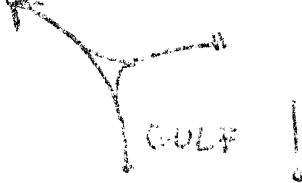
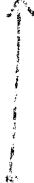

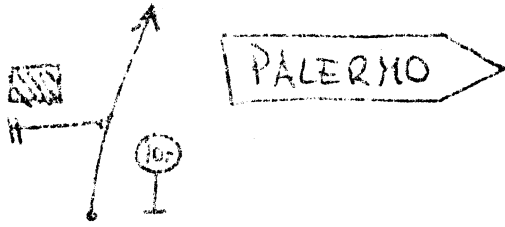
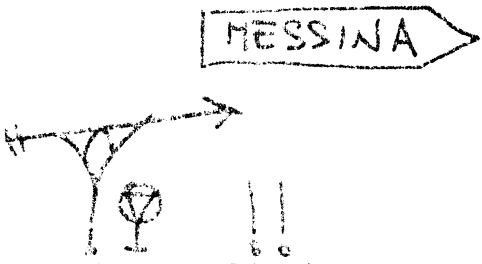
| | | |
|-------|-------|--|
| 0.000 | | C.O. 41 → C.O. 42 PIANO FATE → CEFALU' (ARRIVO) 48' <i>Km 29/48</i> +15 ^{FINISH} |
| 0.060 | 0.060 | ↑ START P.S. F/2 "PIANO FATE" |
| 3.480 | 3.420 | ↖ CAVA, AUTOCARRI QUARRY, PARKING TRUCKS !! |
| 5.190 | 1.710 | ↗ |
| 5.290 | 0.100 | ↗ |
| 5.410 | 0.120 | ↗ ! |
| 5.770 | 0.360 | ↗ |

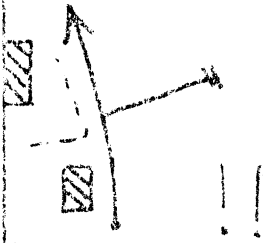
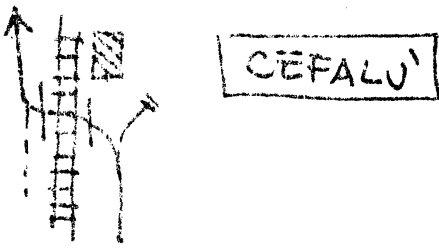
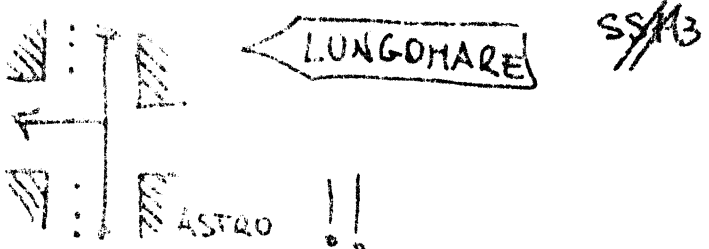
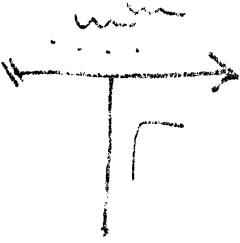
53

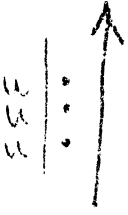
| | | |
|--------|-------|--|
| 10.370 | 4.600 |  |
| 16.920 | 6.550 |  <p>FINE END P.S. F/2</p>  |
| 16.980 | 0.060 |  <p>LASCARI</p> |
| 17.200 | 0.220 |  |
| 17.940 | 0.740 |  |
| 18.030 | 0.090 |  |
| 18.330 | 0.300 |  <p>LASCARI</p> |

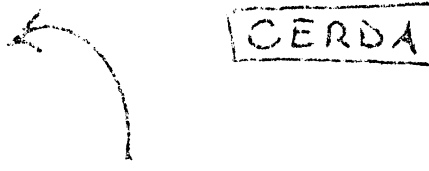
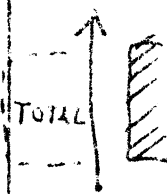
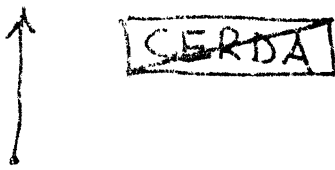
| | | | |
|--------|-------|--|------------------|
| 18.540 | 0.210 |  | |
| 19.480 | 0.940 |  | SS113 |
| 24.480 | 5.000 |  | SS113 |
| 27.170 | 2.690 |  | SS113 |
| 28.000 | 0.830 |  | SS113 |
| 28.510 | 0.510 |  | SS113 |
| 28.710 | 0.200 |  | |

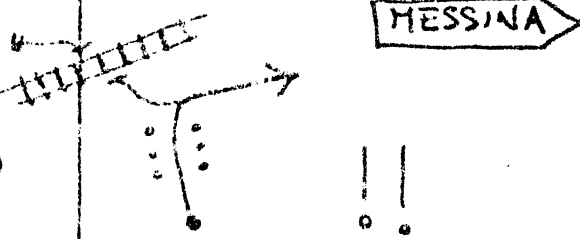
| | | |
|--------|-------|--|
| 28.790 | 0.080 |  <p>C.O. 42 ARRIVO FINISH</p> |
| | | CONGRATULAZIONI! |
| | | <p>SEGUIRE LE INDICAZIONI PER IL PARCO CHIUSO.</p> <p>FOLLOW SIGNS TO PARC FERME.</p> |
| | | <p>C.O. 43 - PARCO CHIUSO PARC FERME</p> |
| | | |
| | | |
| | | |

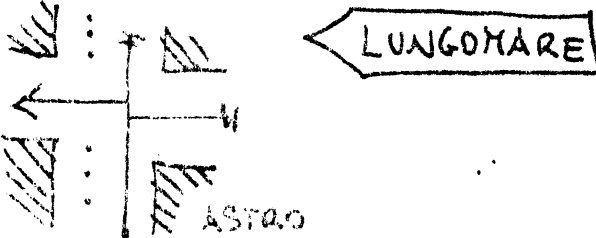
| | | | |
|--------|--------|--|--------------------------------------|
| 22.680 | 1.500 |  | VALE SOLO PER IL TROFEO AUTOBIANCHI. |
| 23.280 | 0.600 |  | |
| 23.330 | 0.050 |  | |
| 29.640 | 6.310 |  | |
| 30.040 | 0.400 |  | |
| 54.830 | 24.790 |  | |
| 55.340 | 0.510 |  | |

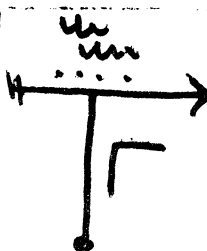
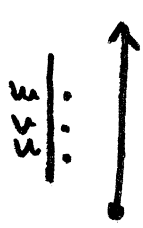
| | | | |
|--------|-------|---|------------------|
| 55.540 | 0.200 |  | |
| 55.620 | 0.080 |  | C.O.42 ARRIVO |
| | | CONGRATULAZIONI! | |
| | | SEGUIRE LE INDICAZIONI PER IL PARCO CHIUSO | |
| | | C.O.43 - PARCO CHIUSO | |
| | | | |
| | | | |

